

PUMP
PFD1/PFS1
OPERATING INSTRUCTIONS

SAINT-GOBAIN PERFORMANCE PLASTICS ASTI
(Headquarters)

41, boulevard des Bouvets
F-92741 NANTERRE CEDEX
Tel: 33. (0) 1.55.68.59.59
Fax: 33. (0) 1.55.68.59.68

SAINT-GOBAIN PERFORMANCE PLASTICS ASTI
(Factory)

E.A.D.A.C. des Berthilliers
F-71850 CHARNAY LES MACON
Tel: 33. (0) 3.85.20.27.00
Fax: 33. (0) 3.85.29.18.48

SAINT-GOBAIN PERFORMANCE PLASTICS

7301 Orangewood Avenue
GARDEN GROVE, CA 92841
Phone: 1 (714) 630 5818
Fax: 1 (714) 688 2416

<http://www.astipure.com> - <http://www.plastics.saint-gobain.com>

PFD1/PFS1 – OPERATING INSTRUCTIONS

INDEX	Page
I – General	2
I.1 – Introduction	
I.2 – Materials	
I.3 – Operation description	
I.4 – Pump Data	
II – Quick checklist	2
II.1 – Shipment	
II.2 – Reception	
III – Installation and operation	3
III.1 – Testing	
III.2 – Set up	
III.3 – Connections	
III.3.1 – Air/nitrogen connections	
III.3.2 – Fluid connections	
III.4 – Initial tests and Adjustments	
IV – Applications	4
IV.1 – Chemical compatibility	
IV.2 – Contamination	
IV.3 – Temperature range	
IV.4 – Applications	
IV.5 – Limitations of use	
V – Maintenance	5
V.1 – Trouble shooting	
V.2 – Preventive maintenance	
V.2.1 – Continuous operation	
V.2.2 – Intermittent operation	
V.3 – Comments	
VI – Dismantling and Repair	6
VI.1 – How to dismantle	
VI.2 – Examination	
VI.3 – Stripping and assembling the pump	
VI.3.1 – Replacing the shuttle valve	
VI.3.2 – Replacing the bellows	
VI.3.3 – Replacing the central shaft and shaft composite rings	
VI.3.4 – Replacing the PTFE sleeves	
VI.3.5 – Replacing the bellow and body O.rings	
VI.3.6 – Replacing the manifold O.rings	
VI.3.7 – Replacing other parts	
VII – Warranty	11
Appendix: Spare parts list	
Maintenance kits	
Section view (drawing “APP 1 REF”)	
Part numbers table (“APP 1 REF”)	
General arrangement drawing (drawing “APP 1 EXT”)	
Flow rate/discharge pressure curves	
Pneumatic diagram (drawing “APP 1 CAB”)	

PFD1/PFS1 – OPERATING INSTRUCTIONS

Thank you for selecting a SAINT-GOBAIN PERFORMANCE PLASTICS ASTI model PFD1 AstiPure™ pump, series 2 (or PFS1: slurry applications).

I – General

I.1 – Introduction

The Model PFD/PFS is a pneumatically operated **TEFLON®** pump. There are no internal or external metal parts.

The pump is designed for handling corrosive, inflammable and sterile fluids. It meets the requirements of the semiconductor, pharmaceutical and chemical industries.

I.2 – Materials

All wetted parts are manufactured in **TEFLON®** PFA HP and PTFE.

Other parts are made of high-tech plastics such as PVDF, PEEK etc.

There are no metal parts.

I.3 – Operation

The pump is pneumatically operated; two bellows joined by a central shaft reciprocate horizontally. The suction and delivery strokes alternate from one side of the pump to the other.

The pump is self-priming and has four balls, which seat on lip seals (check valves).

The pumping frequency of a bellows pump is much slower than an equivalent diaphragm pump and results in an extended life for the bellows.

Pulsation dampers with wetted parts in **TEFLON®** PFA and PTFE are available as an option. This dampens the pulse by approximately 65 to 80%. The pulsation damper for the PFD1/PFS1 pump is AMC1/AMS1.

I.4 – Pump Data

Flow rate	2.5 GPM (600 l/h)
Discharge pressure	58 PSI max. (4 bar)
Suction head	10 feet water column (3 m)
Max. air consumption	6 SCFM (10 m ³ /h) NTP
Connections	3/8"x1/2" or 10x13 mm TEFLON® flared tube or 1/2" MNPT thread.
Air connection	1/4" I/D gas female thread Tubing Ø3/32"x5/32" (2.5x4 mm) maximum 10 feet (3 m) < length < 20 feet (6 m)
Weight	4.5 lbs (2 kg)

Also available three larger capacity pumps with optional pulsation dampers:

PFD2/PFS2	Flow rate 5 US GPM (20 l/min)	AMC2/AMS2
PFD3/PFS3	Flow rate 12.5 US GPM (50 l/min)	AMC3/AMS3
PFD4/PFS4	Flow rate 25 US GPM (100 l/min)	AMC4/AMS4

II – Quick checklist

II.1 – Shipment

Pumps are cleaned and assembled in our clean room, then double sealed in plastic bags to ensure they are not contaminated in transit. They are then packed in cartons with Polyethylene protection.

PFD1/PFS1 – OPERATING INSTRUCTIONS

II.2 – Reception

Upon receipt of the pump, please check that:

- The carton has not been damaged in transit. If there is any visible damage, immediately contact the carrier.
- The pump is not damaged. If there are signs of damage, you should report this immediately to SGPPL ASTI or your local distributor.
- An operating instruction manual has been included in each package. Please request another copy if it has not been included.

III – Installation and Operation

III.1 – Testing

All pumps are tested with DI water at the factory in our clean room for:

- Maximum flow rate with no back pressure
- Minimum flow rate with no back pressure
- Flow rate with 58 PSI (4 bar) discharge pressure
- Checked for leakage

III.2 – Set up

The pump must be installed **horizontally** as shown on general arrangement drawing (see appendix “APP 1 EXT”). This drawing also shows the overall dimensions of the pump etc.

The pump must be **positioned on its feet**. If not, the check valves will not seat correctly and the pump may malfunction.

III.3 – Connections

III.3.1 – Air/Nitrogen connection

The pump must be connected to a clean dry air or nitrogen supply. On no account should the air/nitrogen supply be lubricated, oil or water droplets will cause the shuttle valve to malfunction.

Minimum and maximum supply pressure must be between 29 and 72.5 PSI (2 and 5 bar).

For optimum pump operation, we recommend a supply pressure of 51 PSI (3.5 bar).

The ID of the tube supplying the dry air/nitrogen should not exceed 3/32” (2.5 mm). The tube length between the pump and on/off valve should be between 10 feet minimum (3 m) and 20 feet maximum (6 m).

When in aggressive conditions (acid vapors), it is advised to canalize outlet with a tube of minimum ID 1/4” (6 mm).

The pneumatic on/off valve must be 3-way to ensure the shuttle valve on the pump resets itself when the pump is switched off. The flow control valve must be positioned before the 3-way on/off valve (see appendix “APP 1 CAB”).

A remote control box with on/off switch and needle valve (P/N 21 000 04) is available as an optional extra.

PFD1/PFS1 – OPERATING INSTRUCTIONS

III.3.2 – Fluid connections

The pump is self-priming. The inlet is at the bottom and the outlet at the top.

Two optional fittings are available:

- **PFD1 210** or **PFS1 210**: pump is supplied with flared fittings suitable for 3/8"x1/2" (10x13 mm) **TEFLON**[®] tube. The tube needs to be flared prior to fitting using SGPPL ASTI forming tool (P/N MF11013).
- **PFD1 221** or **PFS1 221**: pump is supplied with 1/2" MNPT male threads on the inlet and outlet. We recommend using **TEFLON**[®] tape when connecting female tube fittings to the PFD/S1 221 pump.

Both the inlet and outlet fittings can be rotated through 180 degrees if necessary, by loosening the nuts on the inlet and outlet fittings. Then, retighten the nuts.

III.4 – Initial Tests and Adjustments

Before commissioning the pump, we recommend to test it dry with a supply pressure of 72.5 PSI (5 bar) to ensure the system works correctly (See III.3.1 for the correct connections).

If the pump is cycling too quickly reduce the speed by adjusting the needle valve.

Before using the pump with chemicals please check:

- The body rings (P/N 2706, Mark L) and manifolds are tight,
- The air/nitrogen supply is dry, clean and between 29 and 72.5 PSI (2 and 5 bar),
- The inlet and outlet fluid connections are correctly fitted and tight.

IV – Applications

IV.1 – Chemical compatibility

All PFD/PFS pump wetted parts are manufactured in **TEFLON**[®] PTFE and PFA and are suitable for pumping even the most corrosive concentrated chemicals: H₂SO₄, HNO₃, HF, H₃PO₄, HCl, NH₄OH, KOH, NaOH, CH₃COOH, TMAH, H₂O₂...

The viscosity of the liquids must be less than 1000 cpo.

PFD pumps can pump liquids containing particles up to 0.02" (0.5 mm).

Very abrasive liquids are not recommended.

Please call either the factory or your local distributor if you require information on chemical compatibility.

IV.2 – Contamination

The "all plastic" construction of the PFD/PFS pump ensures no ionic contamination of the chemical, even if there is a bellows failure.

Due to the low frequency and amplitude of the bellows pump, SGPPL ASTI guarantees a lower level of particle contamination when compared to a diaphragm pump.

IV.3 – Temperature range

The pump can handle liquids from 32°F (0°C) up to +212°F (100°C).

When the fluid temperature is greater than 140°F (60°C) you must frequently check that the body rings (P/N 2706, Mark L) and manifolds are fully tight and that supply pressure is less than 43.5 PSI (3 bar).

For special applications call SGPPL ASTI or your local distributor.

PFD1/PFS1 – OPERATING INSTRUCTIONS

IV.4 – Applications

The PFD/PFS pump is a volumetric pump. The stroke volume is dependent on the flow rate and discharge pressure.

In order to know the precise flow rate of the pump, a paddle wheel flow transmitter can be fitted on outlet. For PFD1/PFS1 the part number of the flow transmitter is DP11013.

- Part number marked **K** (PFD1 210K or PFS1 210K) indicates that the pump will be supplied with **KALREZ**[®] manifold (P/N 2745K, Mark G) and body O.rings (P/N 2739K, Mark H).

PFS1 pumps are equipped with valve seats without lip (P/N 2711A, Mark I) and bellows with rounded spires (P/N 2613S, Mark F) in order to pump abrasive products (slurry).

Common applications are:

- Semiconductor Industry: Transfer of ultrapure and corrosive chemicals.
Pump filter recirculation systems.
- Pharmaceuticals and Chemicals: Chemical injection and sampling.

IV.5 – Limitations of use

The standard pumping speed of the PFD1/PFS1 is about 135 strokes/min.

The following should NOT be part of the system:

- Do not connect the pump inlet or outlet with air, nitrogen or liquid under pressure,
- Lubricated and/or wet air/ nitrogen,
- Air supply tubing greater than 3/32" (2.5 mm) ID,
- Air line length between the pump and control valve less than 10 feet (3 m) and more than 20 feet (6 m),
- Air pressure less than 29 PSI (2 bar) or greater than 72.5 PSI (5 bar),
- Inlet connection less than 3/8" (9 mm) ID,
- Restricted suction side (valves, filters...),
- Exceed the recommended liquid temperatures,
- Pumping too viscous or abrasive liquids.

Any of the above may be detrimental to the normal operation and life expectancy of the pump and may invalidate the warranty.

If the pump is being used with very corrosive chemicals or if it is left for extended periods not in use, we recommend the system is emptied and flushed.

V – Maintenance

V.1 – Trouble Shooting

If the pump stops for any reason check:

- The air/nitrogen supply,
- That all valves in the chemical lines are open.

Before dismantling the pump, ensure the shuttle valve is in the correct position. Depress the manual override on the shuttle valve (P/N 2701, Mark A) to re-position the shuttle.

PFD1/PFS1 – OPERATING INSTRUCTIONS

If the pump starts, check that the following was not the cause:

- The air/nitrogen connections (See III.3.1),
- The air/nitrogen quality,
- Has the pump been serviced correctly? (See V.2 Preventive maintenance).

Before dismantling the pump check the following:

- The air/nitrogen supply is “OFF”,
- The chemical and discharge lines are empty and there is no pressure,
- All in line valves are closed,
- **You follow your local Health and Safety Regulations with regard to particular chemicals.**

V.2 – Preventive Maintenance

V.2.1 – Continuous Operation

When the pump is used continuously, it is necessary to replace the following parts every year:

- Shaft composite rings P/N 7135F
- Central shaft P/N 2615

Important: these parts should always be replaced together.

During routine maintenance checks, examine the following parts and change them if necessary:

- Bellows P/N 2613 (PFD) or 2613S (PFS)
- Shuttle valve P/N 2701
- Viton bellow O.ring P/N 2725
- Body O.ring P/N 2739
- Manifold O.ring P/N 2745
- Lip seal P/N 2711 (PFD) or 2711A (PFS)
- PTFE sleeves P/N 7220
- Silencers P/N 7185
- Ball valves P/N 2712

V.2.2 – Intermittent operation

If the pump is used intermittently, it is advised to replace all wearing parts every 18 months (shaft composite rings and central shaft) and to check other parts (bellows, shuttle valve, lip seal...).

If the pump is left standing full of chemical for long periods all the Viton O.rings should be replaced.

V.3 – Comments

If the pump is used to pump hot chemicals in excess of 140°F (60°C) the preventive maintenance schedule time scale should be divided by 2:

- Every 6 months check as for continuous operation,
- Every 9 months check as for intermittent operation.

The above is based on SGPPL ASTI's experience.

SGPPL ASTI cannot be held responsible for premature failures if the pump is misused or damaged due to an incorrect application.

VI – Dismantling and Repair

Attention: Part numbers quoted in this manual are those used on a “standard” PFD/PFS pump. Before ordering, please check the spare parts list, the section view of the pump and the part numbers table (see encl. documents).

PFD1/PFS1 – OPERATING INSTRUCTIONS

VI.1 – How to dismantle

Before dismantling the pump, refer to the Maintenance schedule V.1, and proceed as follows:

- Disconnect the air/nitrogen supply,
- Remove the inlet and outlet connections (beware of any chemical droplets remaining on the inside),
- Rinse the outside of the pump in DI water to remove all trace of chemicals,
- Remove pump support screws.

VI.2 – Examination

To comply with your local Health and Safety Regulations it is essential the pump and all parts are thoroughly cleaned both on the inside and outside.

See V.2 for the Preventive Maintenance Schedule.

To repair the pump, refer to schedules V.1 and V.2.1.

VI.3 – Stripping and assembling the pump

The SGPPL ASTI design ensures that the pumps are easy to strip and assemble.

The only tools required are a screwdriver to replace the shuttle valve (see VI.3.1) and a strap wrench to remove body rings (P/N 2706, Mark L). All other items can be removed and replaced by hand. A tools kit for the whole maintenance is available (P/N KPF1), as well as maintenance kits (P/N AIR PFD1, LIQ PFD1, and MEC PFD1), and a preventive maintenance box (P/N PM PFD1 or PM PFS1). For more details on these kits, please report to appendix documents.

Please refer to drawing “APP 1 REF” to visualize marks and part numbers quoted hereafter.

VI.3.1 – Replacing the shuttle valve

The valve is easily removed from the outside:

- 1) Unscrew the 2 fastening screws – take care not to damage them,
- 2) Replace with a new factory assembled shuttle valve (P/N 2701, Mark A),
- 3) Carefully tighten the 2 fastening screws. **Do not overtighten,**
- 4) Test with compressed air/nitrogen. Re-tighten if necessary.

VI.3.2 – Replacing the bellows

To replace the bellows proceed as follows:

- 1) Remove shuttle valve (P/N 2701, Mark A) (see VI.3.1),
- 2) Unscrew exhaust silencers (P/N 7185),
- 3) Unscrew the 4 manifold nuts and remove the 4 balls valves (P/N 2712) – take care not to lose them,
- 4) Remove the 4 manifold O.rings (P/N 2745, Mark G),
- 5) Position the pump into a bench vice (tighten only over the core P/N 2708),
- 6) Unscrew the body ring (P/N 2706, Mark L) with a strap wrench while holding the PFA body,
- 7) Remove the pump body (P/N 7145, Mark K),
- 8) Now unscrew the bellows (P/N 2613 or 2613S, Mark F) from the central shaft (P/N 2615, Mark D),
- 9) Replace with new bellows – moderately hand tighten,
- 10) To re-assemble follow the above but in reverse order from 8) to 1).

All **TEFLON®** PTFE and PFA parts are soft; please handle with care to avoid damage. **Do not put them down on their sealing surfaces.**

To re-assemble the PFA bodies, hand tighten the body rings (P/N 2706, Mark L), and block them up by giving 1/8 further turn with the strap wrench. Check that bodies are well positioned so that manifolds are tight.

PFD1/PFS1 – OPERATING INSTRUCTIONS

VI.3.3 – Replacing the central shaft and shaft composite rings

Follow the same steps described in V1.3.2 until 8) then:

- 9) Remove the central shaft (P/N 2615, Mark D),
- 10) Remove the plastic caps (P/N 1028),
- 11) Remove the C-PEEK plate screws (P/N 2729) and the rings (P/N 1720),
- 12) Remove the 4 shaft composite rings (P/N 7135F) from plates (P/N 2709 and 2728, Marks B and C),
- 13) Clean the plates and the core (P/N 2708) by removing the dust from previous wear by O.rings,
- 14) Insert 4 new composite rings with tools from our tool kit (P/N KPFD1) as follows:
 - Each of the 4 shaft rings (P/N 7135F) is composed of two parts: one O.ring and one sleeve (Figure 1):

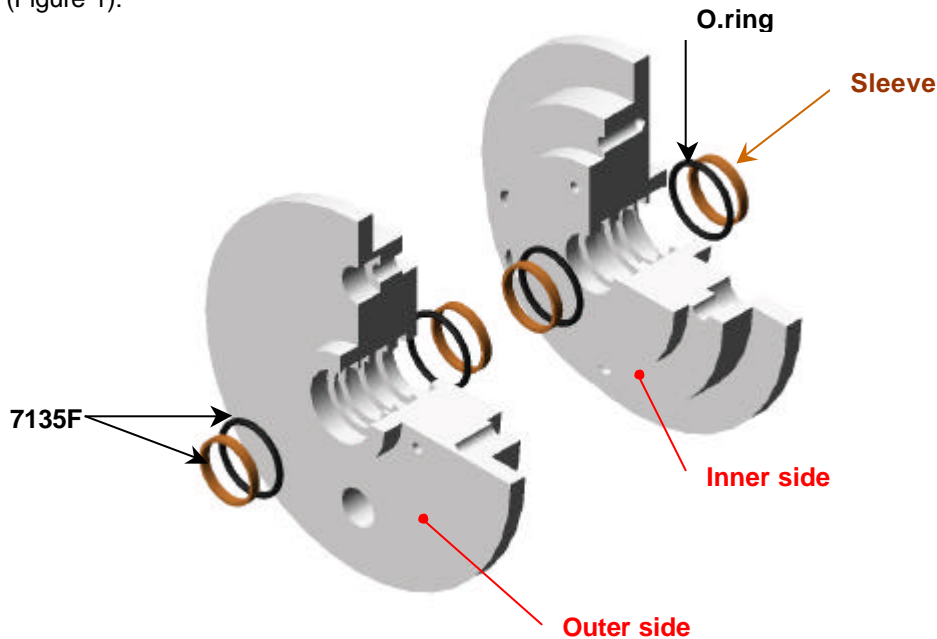

Figure 1

- O.rings can be installed with the O.ring positioning tool P/N 1641. To install the ring on the inner side of the plate (Figure 2), insert the longer side of the tool in the plates (P/N 2709 and 2728, Marks B and C), as shown in the drawing. Then place the ring against the O.ring positioning tool (P/N 1641) and insert it in the groove.

To install the ring on the outer side (Figure 3), insert the shorter side of the O.ring positioning tool through the inner side of the plate, and place the ring against the positioning tool. Then insert the ring in its groove.

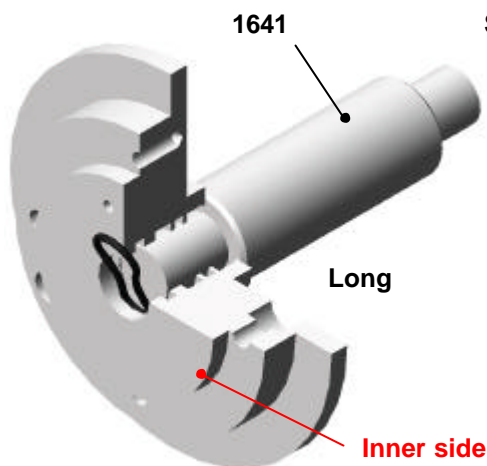

Figure 2

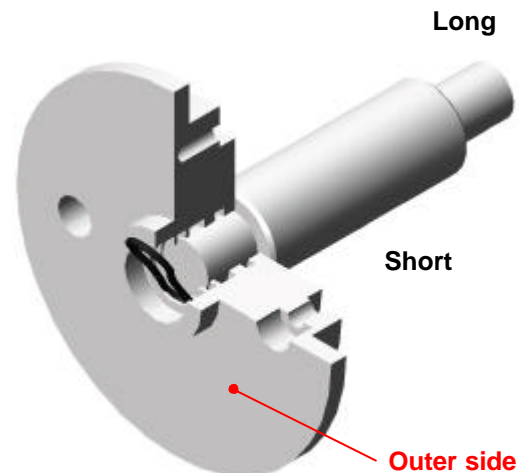

Figure 3

PFD1/PFS1 – OPERATING INSTRUCTIONS

- Squeeze the sleeve into a “bean” shape, then insert it in the sleeve insertion tool P/N 2680 (Figure 4):

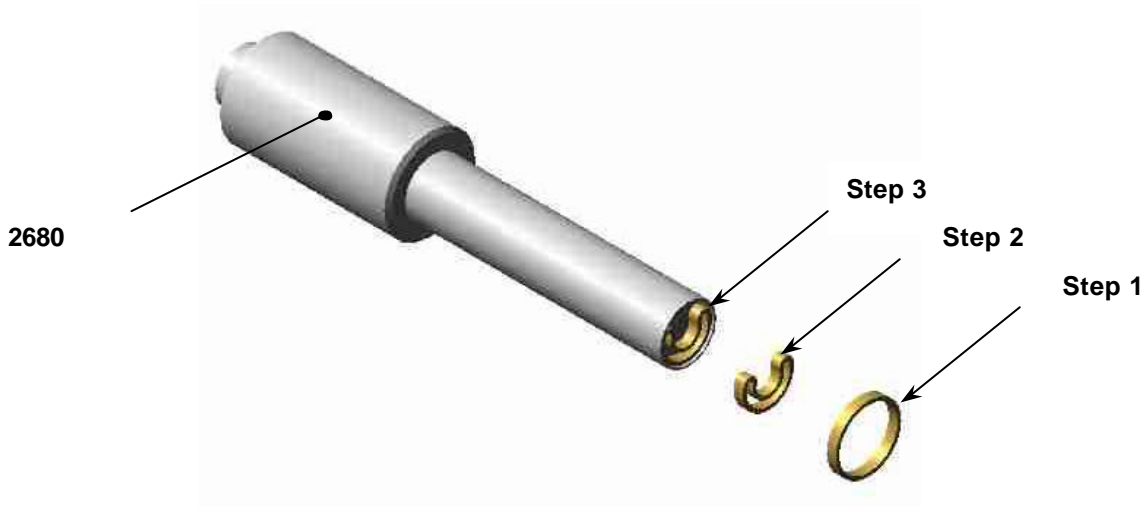

Figure 4

- While holding the O.ring positioning tool (P/N 1641) against the plate, place the sleeve insertion tool (P/N 2680) into the other side and use the push-button to release the sleeve free on the O.ring (Figures 5 & 6):

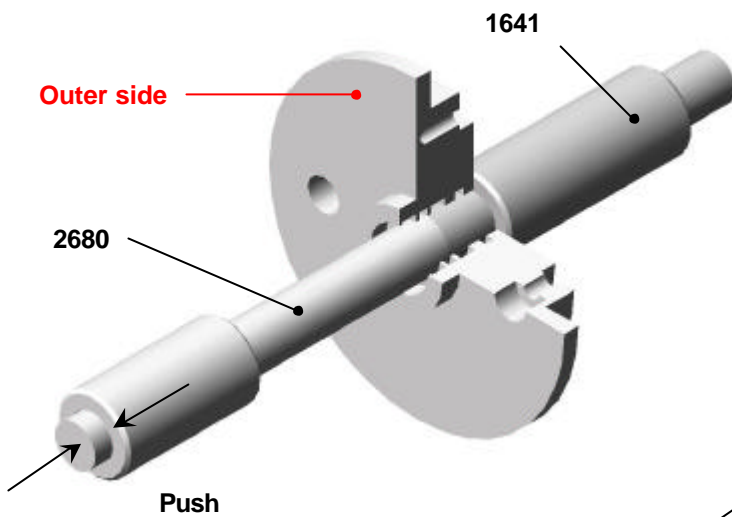

Figure 5

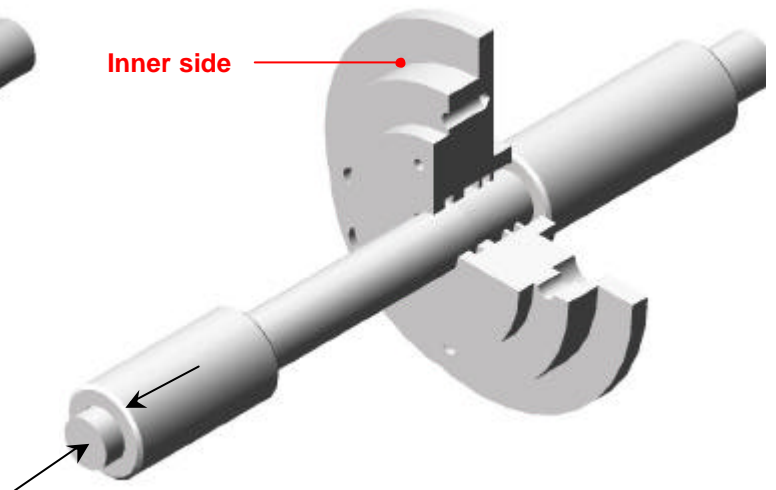

Figure 6

PFD1/PFS1 – OPERATING INSTRUCTIONS

- Use the pick (P/N 1643) to correctly position the sleeve in its groove. Be careful not to damage the sleeve (Figure 7):

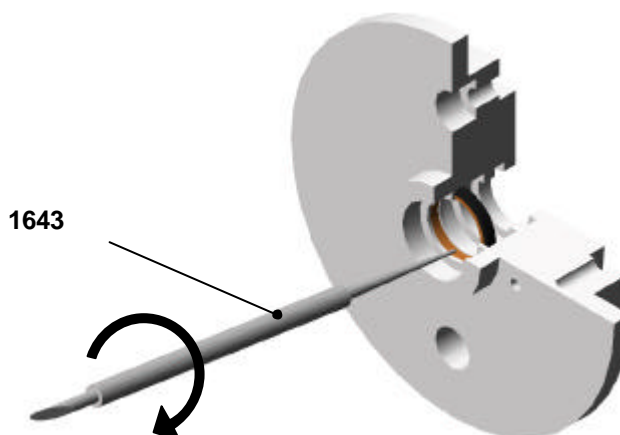

Figure 7

- Repeat this operation for the 4 sets of rings.
- 15) Fit the plates and the body rings (P/N 2706, Mark L) on the core (tighten moderately the screws P/N 2729), insert first the O.ring (P/N 1720) under the screw head,
 - 16) Fit new plastic caps (P/N 1028) so that tightness between the core and the plates is ensured,
 - 17) **Important:** lightly wipe the central shaft and shaft composite rings with **silicon grease (Molykote 111)** before re-assembly. Then insert the central shaft without turning it when threaded part reaches the O.rings,
 - 18) To re-assemble follow the above instructions but in reverse order.

VI.3.4 – Replacing the PTFE sleeves

Follow the same procedure as for VI.3.3 until 14); after replacing the composite rings, remove the PTFE sleeves (P/N 7220) from the groove with a blunt pointed instrument. Clean and re-assemble the new part.

A pump that was not originally fitted with PTFE sleeves can be equipped with sleeves. In this case, you need to change the plates (P/N 2709 and 2728, Marks B and C).

VI.3.5 – Replacing the bellow and body O.rings

After removing the bellows (see V1.3.2, step 8), remove the bellow Viton O.rings (P/N 2725) and the body O.rings (P/N 2739, Mark H¹). Then carefully replace the new ones **without scratching the surface of the bellows (P/N 2613 or 2613S, Mark F) or housing (P/N 7145, Mark K).**

VI.3.6 – Replacing the manifold O.rings

Follow point VI.3.2, steps 3) and 4). Carefully replace the manifold O.rings (P/N 2745, Mark G). Take care as these parts are fragile, **especially the elbow connectors.**

PFD1/PFS1 – OPERATING INSTRUCTIONS

VI.3.7 – Replacing other parts

When dismantling the pump or control unit for service, components found damaged should be replaced. Alternatively, the pump/control unit can be returned to your distributor or SGPPL ASTI for examination, estimate, and repair.

Important: Please indicate what chemical was handled, the frequency of use, and the reason for returning the pump.

A receipt note “Conditions of use” is at your disposal. Do not hesitate to ask for it when needed. An estimate for repair will be proposed to you and the pump will be returned to you within one week from date of its acceptance.

VII – Warranty

SGPPL ASTI pumps and accessories are warranted for all parts and labor against faulty workmanship (return to factory) for one year from delivery date (9000 hours of use).

SGPPL ASTI is not responsible for damage to its products through improper installation, maintenance, use or attempts to operate them beyond their mechanical capacity, intentionally or otherwise, or for unauthorized repair.

SGPPL ASTI shall not be liable for any indirect, special, incidental or consequential damages resulting from the use, failure or malfunction of any product.

PFD1/PFS1 – SPARE PARTS LIST

SAINT-GOBAIN PERFORMANCE PLASTICS ASTI

41 boulevard des Bouvets
 F- 92000 NANTERRE
 Tel: +33 (0) 1.55.68.59.59
 Fax: +33 (0) 1.55.68.59.68
<http://www.astipure.com>
<http://www.plastics.saint-gobain.com>

PUMPS PFD1 (SERIES 2) & PFS1

PART NUMBER	DESIGNATION	QUANTITY			
		PFD1 210	PFD1 221	PFS1 210	PFS1 221
1028	CAP	4	4	4	4
1720	FLAT PLATE O RING	4	4	4	4
2559A	PFD1 MANIFOLD TUBE 1/2"	2		2	
2559AZ	PFD1Z MANIFOLD TUBE 1/2"	2		2	
2560A	PFD1 MANIFOLD PIPE THREAD 1/2 MNPT		2		2
2560AZ	PFD1Z MANIFOLD PIPE THREAD 1/2 MNPT		2		2
2613	PFD1 BELLOW WITH INSERT	2	2		
2613S	PFS1 BELLOW ROUNDED SPIRES WITH INSERT			2	2
2615	CENTRAL SHAFT	1	1	1	1
2701	SHUTTLE VALVE	1	1	1	1
2701F	SHUTTLE VALVE PE UHMW SHUTTLE	1	1	1	1
2706	BODY RING	2	2	2	2
2706T	ETFE BODY RING	2	2	2	2
2708	CORE	1	1	1	1
2709	BLADED PLATE	1	1	1	1
2711	PFD1 LIP SEAL	4	4		
2711A	PFS1 SLURRY VALVE SEAT			4	4
2712	BALL VALVE Ø10	4	4	4	4
2725	VITON BELLOW O.RING	2	2	2	2
2728	TAPPED PLATE	1	1	1	1
2729	C-PEEK 5x50 PLATE SCREW	4	4	4	4
2739	FEP BODY O.RING	2	2	2	2
2739K	KALREZ BODY O.RING	2	2	2	2
2745	FEP MANIFOLD O.RING	4	4	4	4
2745K	KALREZ MANIFOLD O.RING	4	4	4	4
7135F	SHAFT COMPOSITE O.RING	4	4	4	4
7139	VITON PNEUMATIC O.RING	6	6	6	6
7145	PFA BODY	2	2	2	2
7185	1/4" EXHAUST SILENCER	2	2	2	2
7220	PTFE SLEEVE	2	2	2	2
MS11013	PVDF NUT TUBING 1/2" OD	2	2	2	2

PFD1/PFS1 – MAINTENANCE KITS

SAINT-GOBAIN PERFORMANCE PLASTICS ASTI

41 boulevard des Bouvets
 F- 92000 NANTERRE
 Tel : +33 (0)1.55.68.59.59
 Fax : +33 (0)1.55.68.59.68
<http://www.astipure.com>
<http://www.plastics.saint-gobain.com>



PUMP PFD1 (SERIES 2) – MAINTENANCE KITS

PART NUMBER	DESIGNATION	QUANTITY			
		AIR PFD1	LIQ PFD1	MEC PFD1	PM PFD1
1028	CAP				4
1720	FLAT PLATE O RING				2
2613	PFD1 BELLOW WITH INSERT		2		2
2615	CENTRAL SHAFT			1	1
2701	SHUTTLE VALVE	1			1
2711	LIP SEAL		4		4
2712	BALL VALVE Ø10		4		4
2725	VITON BELLOW O.RING		2		2
2729	C-PEEK 5x50 PLATE SCREW				2
2739	FEP BODY O.RING		2		2
2745	FEP MANIFOLD O.RING		4		4
7135F	SHAFT COMPOSITE O.RING			4	4
7139	VITON PNEUMATIC O.RING				6
7185	1/4" EXHAUST SILENCER	2		2	2
7220	PTFE SLEEVE				2

PUMP PFS1 – MAINTENANCE KIT P/N “PM PFS1”

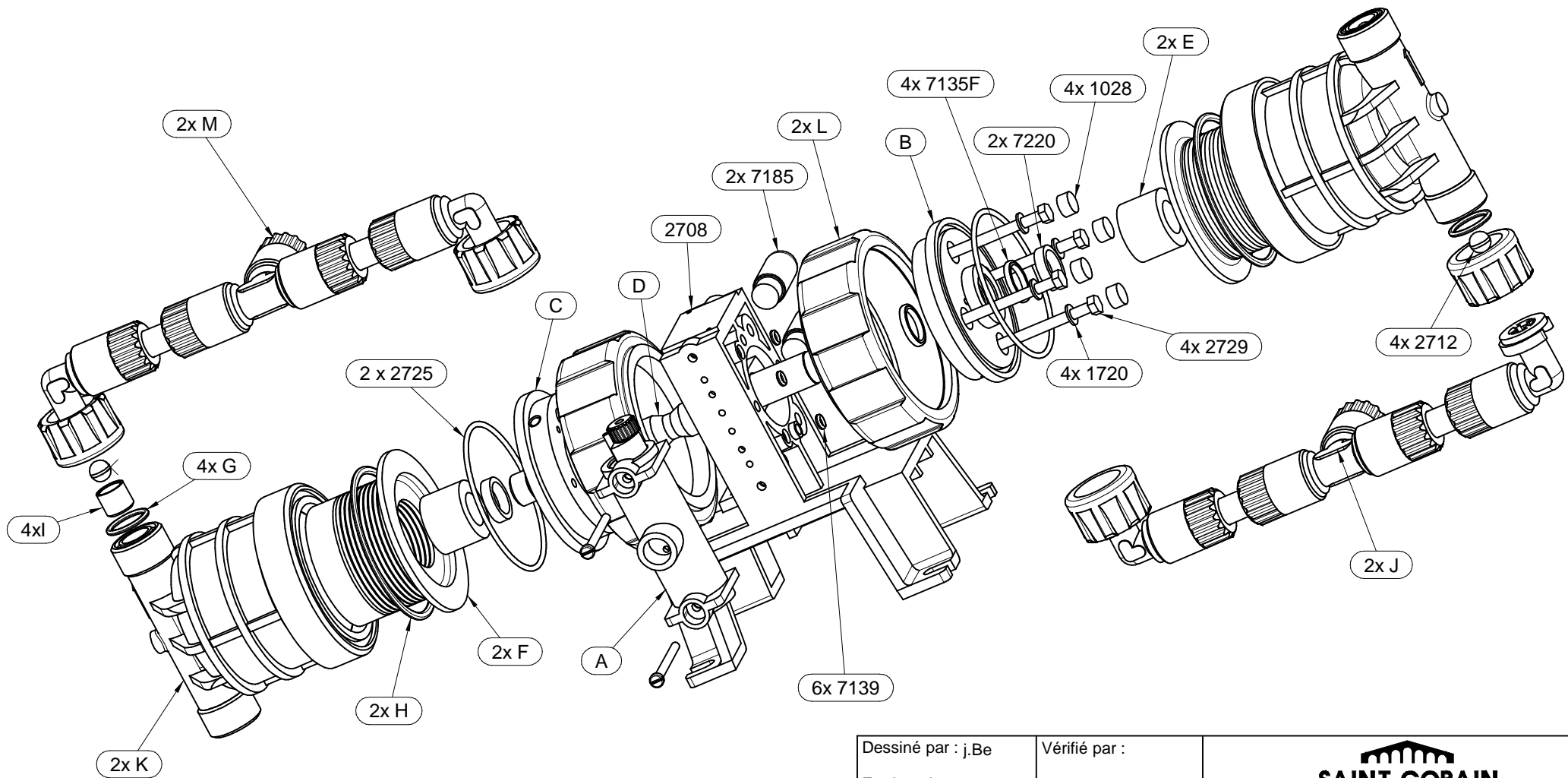
PART NUMBER	DESIGNATION	QUANTITY
1028	CAP	4
1720	FLAT PLATE O RING	2
2613S	PFS1 BELLOW ROUDED SPIRES WITH INSERT	2
2615	CENTRAL SHAFT	1
2701	SHUTTLE VALVE	1
2711A	VALVE SEAT	4
2712	BALL VALVE Ø10	4
2725	VITON BELLOW O.RING	2
2729	C-PEEK 5x50 PLATE SCREW	2
2739	FEP BODY O.RING	2
2745	FEP MANIFOLD O.RING	4
7135F	SHAFT COMPOSITE O.RING	4
7139	VITON PNEUMATIC O.RING	6
7185	1/4" EXHAUST SILENCER	2
7220	PTFE SLEEVE	2



Dessiné par : j.Be	Vérfié par :	 SAINT-GOBAIN PERFORMANCE PLASTICS SAINT-GOBAIN PERFORMANCE PLASTICS ASTI 41 Boulevard des Bouvets 92000 Nanterre - France Tel: +33 (0)1 55 68 59 59 Fax: +33 (0)1 55 68 59 68 http://www.astipure.com
En date du : 24/09/01	En date du :	
DESIGNATION ASTIPURE Pump 1		
REFERENCE APP 1 REF	INDICE 03	

PART NUMBERS TABLE

Piloting	Fluid	Size	Conne- ction	Sealing	Option	A	B	C	D	E	F	G	H	I	J	K	L	M
PF (standard)		1				2701	2709	2728	2615		2613	2745	2739	2711		7145	2706	MS11013
PR		1					2826	2827	2828	2829								
PO		1					2826	2827	2828	2829								
	D	1																
	S	1									2613S			2711A				
			210													2559A		
			221													2560A		
				K								2745K	2739K					
					Z										P/N + "Z"		2706T	
					F	2701F												

IMPORTANT:
The following reference combination is not relevant:
PO - 1 --- - F

PR S 1 210 K F

- A : Shuttle valve
- B : Bladed plate
- C : Tapped plate
- D : Central shaft
- E : Stopper
- F : Bellow
- G : Manifold O.Ring
- H : Body O.Ring
- I : Lip seal
- J : Manifold
- K : Pump body
- L : Body ring
- M : Nut

Piloting:
F Standard
R Recirculation
O No piloting

Fluid:
D Standard
S Slurry

Option:
Z TEFZEL nut
F HF shuttle valve

Connection:
210 Flare Fitting Ø 10x13 or 3/8"x1/2"
221 Pipe thread Ø 1/2" MNPT

Sealing:
- FEP
K Kalrez

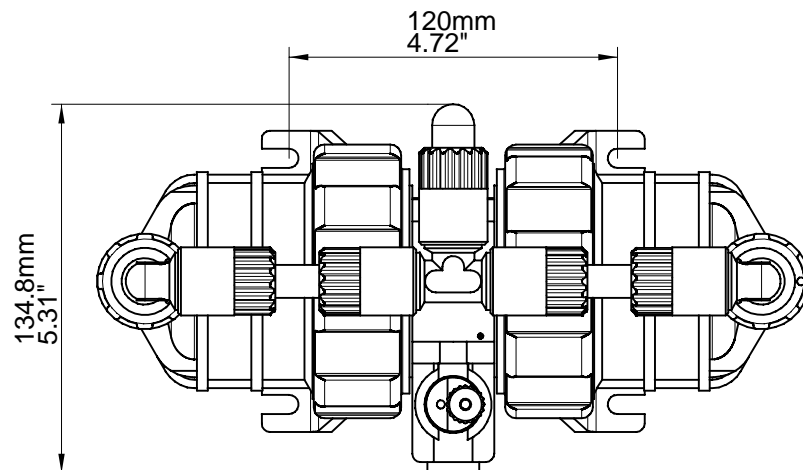
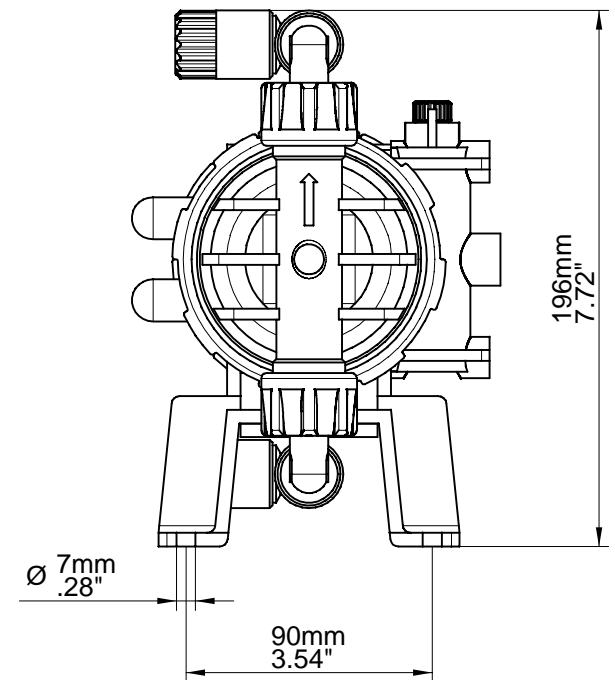
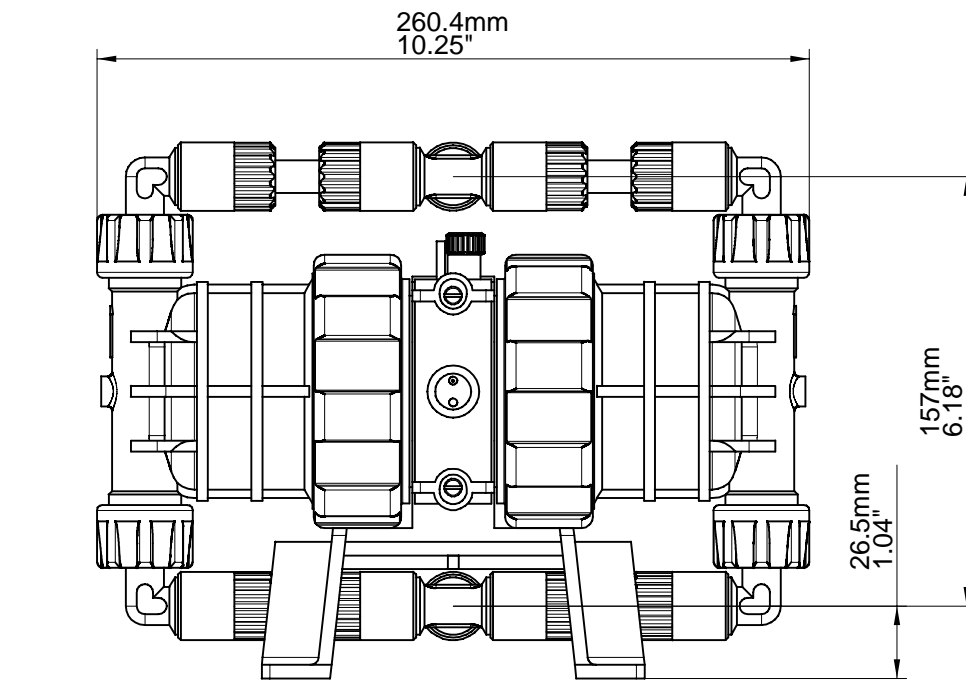
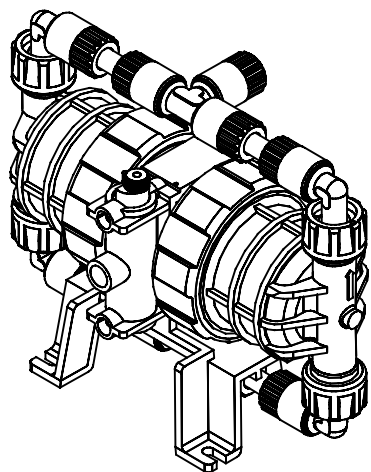

Dessiné par: FM Validé par:	DATE: 02/05/00	SGPPL ASTI 41 Boulevard des Bouvets F-92741 Nanterre Cedex FRANCE
DESIGNATION Pump ASTIPURE 1		
REFERENCE APP 1 EXT	INDICE 00	Tel: +33 (0)1 55 68 59 59 Fax: +33 (0)1 55 68 59 68

AstiPure™ PFD1 / PFS1 pump flow rate characteristics

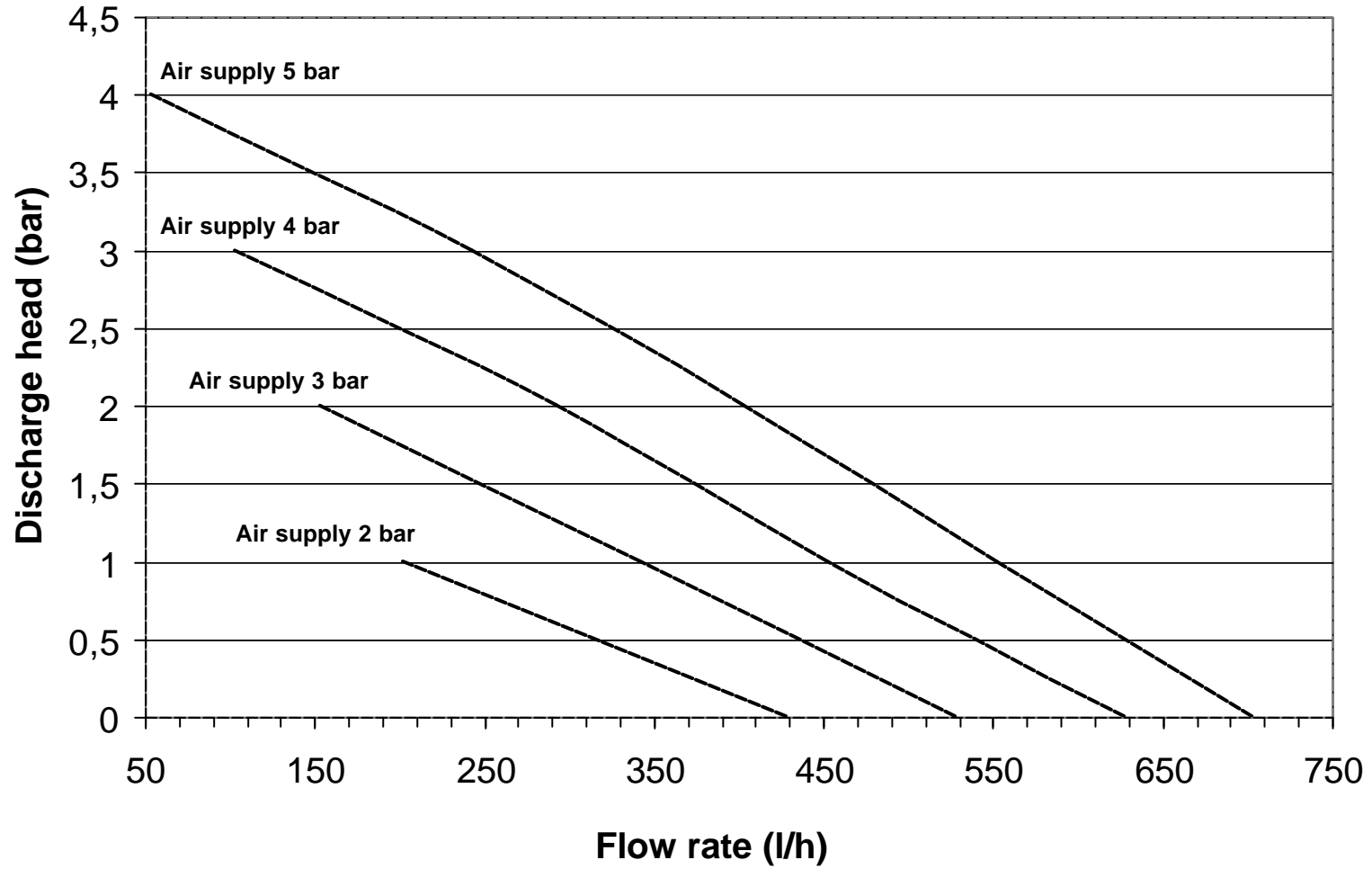

Air 2 à 5 Bar
2m Max

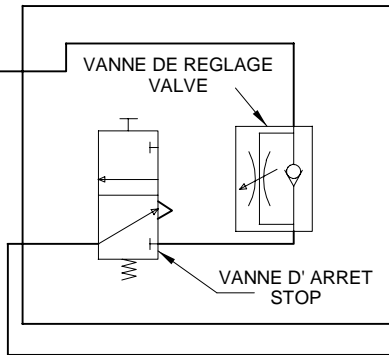

Ø2.5x4mm Max - 6m Max

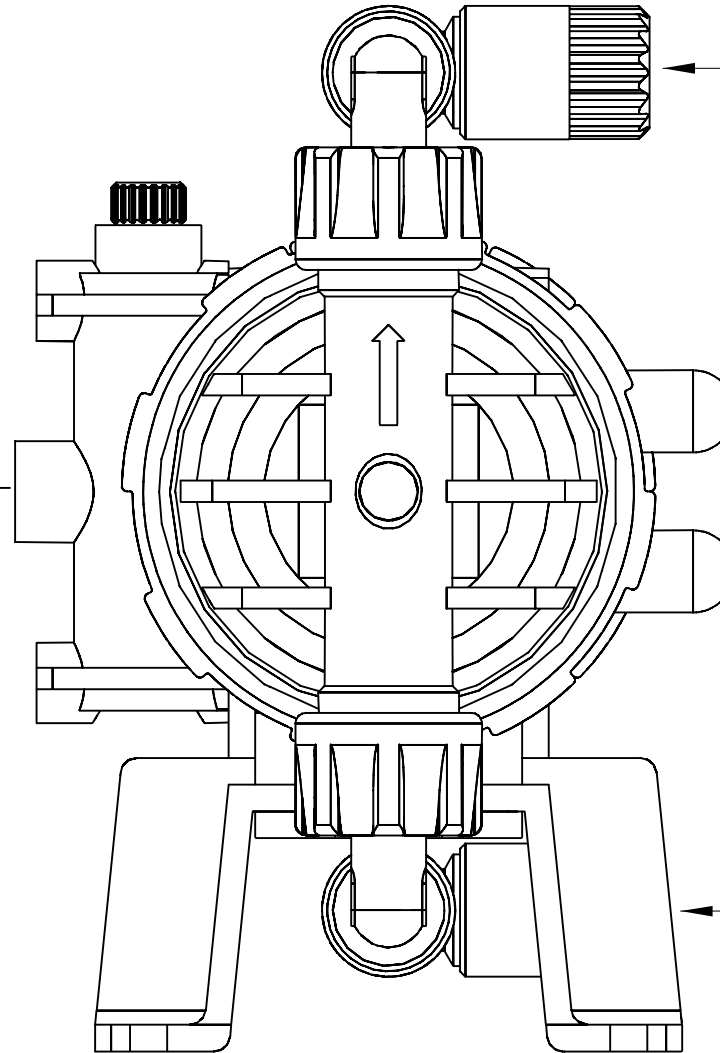

REFOULEMENT FLUIDE
FLUID OUTLET

ASPIRATION FLUIDE
FLUID INLET

Dessiné par: FM Validé par:	DATE: 09/05/00	SGPPL ASTI 41 Boulevard des Bouvets F-92741 Nanterre Cedex FRANCE
DESIGNATION ASTIPURE Pump 1		
REFERENCE APP 1 CAB	INDICE 00	Tel: +33 (0)1 55 68 59 59 Fax: +33 (0)1 55 68 59 68